

# BCR402R: Light Emitting Diode (LED) Driver IC Provides Constant LED Current Independent of Supply Voltage Variation

- Supplies stable bias current for Light Emitting Diodes (LEDs)
- Low Voltage Drop of 0.75V maximizes system DC efficiency
- LED drive current adjustable via single external resistor (20 – 60 mA range)
- Negative temperature coefficient protects LEDs against thermal runaway
- Low Cost, Low External Parts Count, Easy-to-Use, Fast Time-To-Market
- Small Surface-Mount SOT143R packaging (2.9 x 1.6 x 1.1 mm inc. leads)

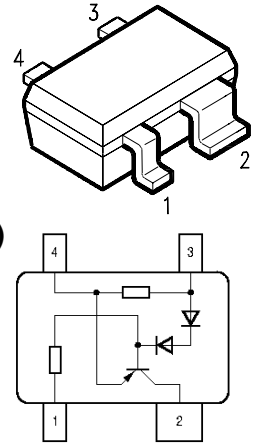

EHA07188

## 1. Introduction

Light-Emitting Diodes (LEDs) and LED displays suffer from varying illumination levels as a result of changes in power supply voltages. This is true for displays used in automotive applications, battery-operated handheld devices, or fixed (architectural) installations. To keep LED brightness constant, it is necessary to stabilize the LED's current over the anticipated power supply voltage variation range.

Often a resistor in series with the LED(s) is used to stabilize current. However, this method has some serious drawbacks. To achieve good LED current stability over the varying supply voltage range, the resistor must take on a large value (infinite resistance, in the ideal case) to make the power supply plus series resistor combination approach the traits of an ideal constant current source having infinite output impedance. In such cases, there is a large voltage drop across this series resistor. For a particular supply voltage, this voltage drop 1) reduces the number of LEDs that can be driven by one resistor, requiring additional parallel resistors with which to drive a given number of LEDs, thereby increasing system current consumption and 2) power is "burned" or wasted as heat in these series resistors.

Infineon's LED driver family, consisting of the **BCR401R**, **BCR402R**, **BCR402U** and **BCR405U**, offers an easy, cost-effective and reliable way to achieve LED current stabilization while overcoming the drawbacks inherent in using a series resistor. These LED driver IC's cover the most commonly used LED supply current ranges – 10mA, 20mA, and 50mA. Refer to **Figures 1 and 2**. In each device, the nominal drive current may be easily adjusted upward from the nominal value by adding a single external resistor – for BCR401R / 402R, connect this resistor between pins 3 and 4.

**Figure 1. Infineon LED Current Driver Family Recommended Current Ranges.**

| Device  | Package | Recommended Current Range | Maximum Power Dissipation |
|---------|---------|---------------------------|---------------------------|
| BCR401R | SOT143R | 10 – 60 mA                | 330 mW *                  |
| BCR402R | SOT143R | 20 – 60 mA                | 330 mW *                  |
| BCR402U | SC74    | 20 – 65 mA                | 500 mW **                 |
| BCR405U | SC74    | 50 – 65 mA                | 500 mW **                 |

\* Soldering Point Temperature  $T_s = 87\text{ }^\circ\text{C}$

\*\* Soldering Point Temperature  $T_s = 117\text{ }^\circ\text{C}$

For selecting the proper resistor value to increase BCR402 drive current above the nominal level of 20mA, refer to **Figure 3**, which

is also found in the BCR402R datasheet. Two cases are shown: “open”, e.g. R1 is omitted (no R1 used), showing nominal current to be 20mA, and R1=68Ω, yielding 30mA. For current up to 60mA, R1 will take on values less than 68Ω, and R1 can be determined experimentally. Note that in all cases,

1. BCR402R output current should be limited to 60mA
2. Total power dissipation of BCR402R should be limited to less than 330 mW for device soldering point temperatures (T<sub>S</sub>) equal to or less than 87 °C.

The power dissipation is simply calculated by multiplying the voltage drop across the device (e.g. voltage between pins 2 and 3) times the device current. A good general reference for use when determining if a given circuit design falls within device power dissipation guidelines may be found at [1].

**Figure 2. Nominal Output Currents of Devices in the Infineon LED Driver Family. Current can be adjusted from these nominal values via use of a single external resistor.**

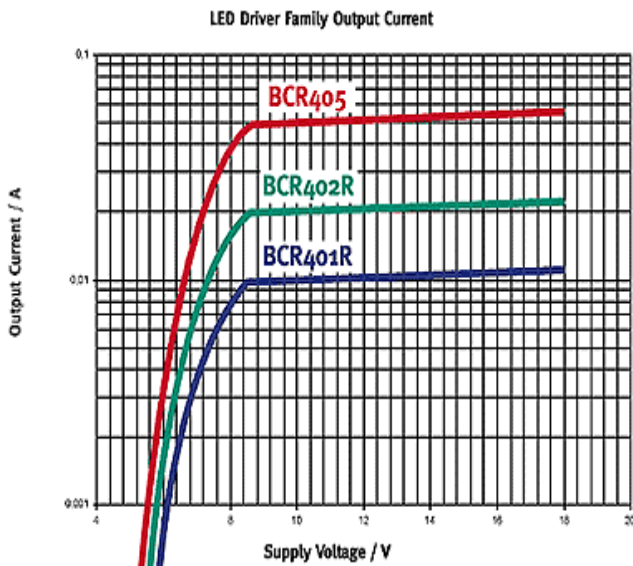
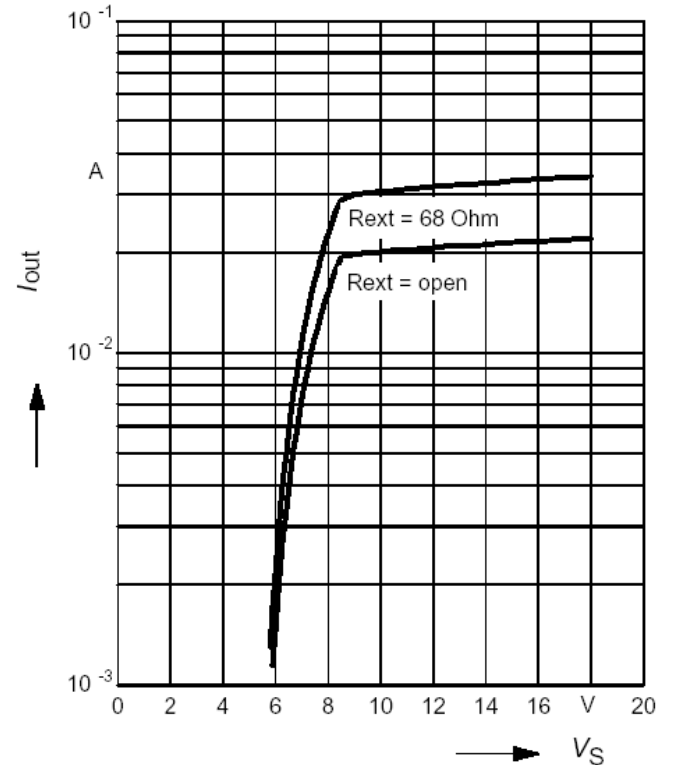

**Figure 3. BCR402R Output Current vs. Supply Voltage for external resistor = OPEN and external resistor = 68Ω.**

**Output current versus supply voltage**

$$I_{out} = f(V_S); R_{ext} = \text{Parameter}$$

Load: two LEDs with  $V_F = 3.8V$  in series



**2. Application Circuit**

The application circuit is designed to demonstrate the difference between stabilizing LED current using an Infineon LED driver IC, versus using a series resistance to stabilize current. **This particular circuit has been initially set up to operate over a supply voltage range of 9V to 16V.** The switch may be used to easily toggle between BCR402R mode and “resistor” mode. Please refer to **Figure 4.**

Figure 4. Application Circuit Schematic. Switch SW1 permits comparison of BCR402R vs. “Resistor Method”.

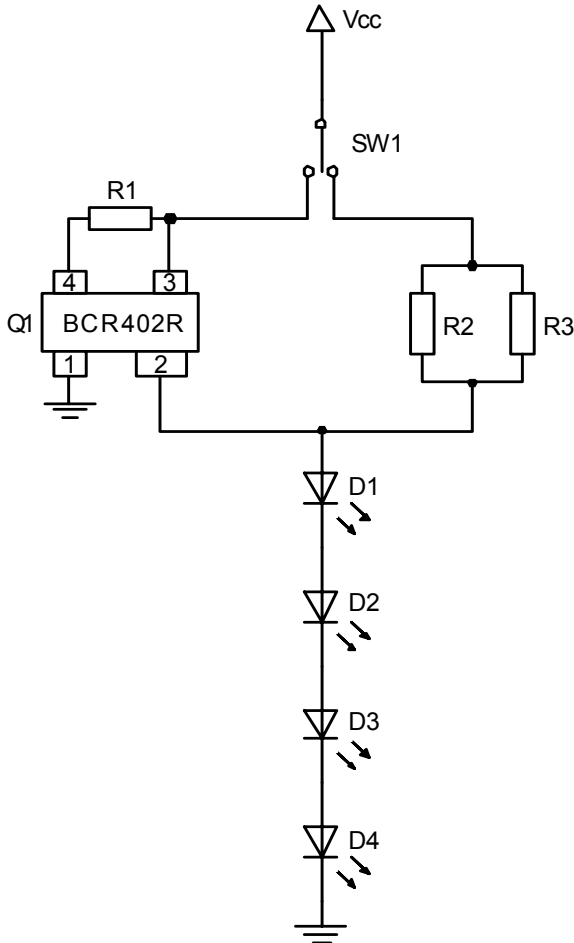

BCR402R has a typical output current of 20mA without using external resistor R1. Current may be increased above this nominal value by using R1, and in this case, R1 was set to 82 Ω to achieve an output current of 29mA. Based on the fact that the minimum supply voltage is 9V and that there is a voltage drop of approximately 0.75V across the BCR402R at minimum supply voltage, it is possible to drive four red LEDs. On the right side of the circuit shown in the schematic (“resistor mode”), two parallel resistors (560Ω) had to be used instead of one, so as to not exceed the maximum power dissipation of the 1208 SMD resistors while achieving a net resistance of 280Ω. **This brings up a key issue: overall system efficiency.** See Figure 5.

Figure 5. Comparison of Power Dissipation in BCR402R LED Bias controller vs. Resistor Biasing Method.

| Power Dissipation in BCR402R | Power Dissipation in (R2+R3) |
|------------------------------|------------------------------|
| 22mW                         | 235mW                        |

For  $V_S=16V$ ,  $I=29mA$ ,  $R_2 || R_3 = 280\Omega$

Compare results in Figure 5 for both sides of the application circuit (e.g. BCR402R method versus Resistor method), for the condition of  $V_S=16V$ ,  $I=29mA$ . When the “resistor method” is used to drive the same number of LEDs as the BCR402R, more than ten times the DC power is wasted in the resistors as is burned in the BCR402R. *The difference in power dissipation between the two methods, 213mW, may seem trivial, unless one considers the effect of using large numbers of such LED circuits in a large display.* If the net series resistor value is reduced, DC power wasted when using the “resistor method” could be reduced, but the already poor current regulation of the “resistor method” gets even worse. If the net series resistor value is increased to 410Ω (two parallel 820Ω resistors), the current stability is improved slightly, but the larger voltage drop across the larger net series resistance reduces the number of LEDs that can be driven from four to just two. For a given number of LEDs in a display, this means that the user of the resistor method would then have to add additional resistor + LED branches to the display, requiring additional current and further increasing power dissipation. *In the example given here, the current consumption would have to double in order to drive a total of four red LEDs with 410Ω series resistances.*

Figure 6 shows the effect on current stabilization using the BCR402R and different series resistor values (280, 340 and 410 Ω, resulting from parallel combinations of R1+R2). Note the nice, flat curve showing nearly constant current over the entire 9V to 16V supply range when the BCR402R LED Bias Controller is used, while the series resistance method shows very limited current stabilization – even with

large resistor values. Again, such large resistor values not only reduce the number of LEDs that can be driven, but waste additional DC power.

**Figure 6. LED Current Stabilization Effect using BCR402R versus Different Series Resistor Values for “Resistor Method”. Note flat current curve over supply voltage when BCR402R is used.**

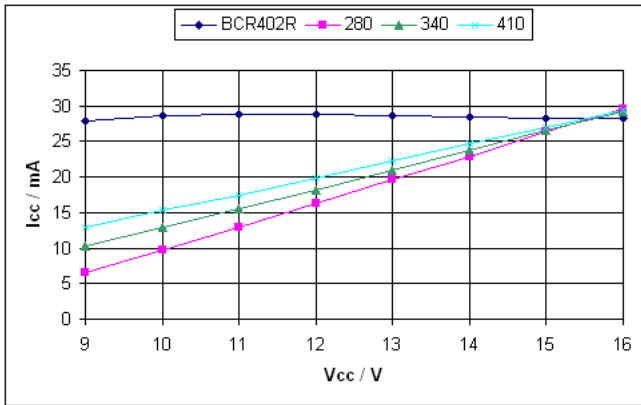

**3. Safe Operation of BCR402R in Systems with Supply Voltages in Excess of Device Maximum Ratings – e.g. Fixed or Architectural Applications (24V).**

For some LED applications, including fixed or “architectural” displays, voltages greater than the 18V maximum rating (pin 3) of the BCR402R may be encountered. For example, +24V is frequently used in so-called architectural displays. This section describes the advantages of using BCR402R in such systems, and how BCR402R may be safely employed in such higher voltage applications by using a “trick”.

These systems typically employ switch-mode power supplies with precise voltage outputs, eliminating the problem of supply voltage variation encountered in automotive or portable applications. However, unless an LED driver like the BCR402R is used, another problem can arise as a result of the typically large variation in LED forward voltages ( $V_F$ ). For example, one type of amber-color LED in widespread use today has a specified forward voltage range of 1.90 to 2.50 volts. Large displays in architectural applications often have many parallel branches of LEDs. In a display using only resistors for current stabilization, if one

branch or “stack” of LEDs consists of diodes with  $V_F$ 's in the low end of the specified range, and another stack consists of LEDs with higher  $V_F$ 's, the stack with the lower forward voltages can “hog” or draw more current than the other stack(s). This can create a situation where the customer may readily see differences in brightness between the adjacent stacks of LEDs. To make matters worse, LEDs have a negative temperature coefficient for forward voltage as regular PN junctions do – but frequently higher in magnitude (e.g.  $-4\text{mV} / ^\circ\text{C}$  for an LED, versus  $-2.3\text{mV} / ^\circ\text{C}$  for a typical PN junction). Since the stack of LEDs consisting of diodes with lower forward voltages will draw more current, they will tend to heat up more than adjacent branches, which will further decrease their forward voltage, making them draw more current, and so on, potentially creating a thermal runaway condition and failure mode. The key point: if each stack of LEDs were fed with an LED Driver device like BCR402R instead of employing a resistor, the current through each stack of diodes would be stabilized, and LED stack currents would be more uniform regardless of the normal variation in LED forward voltages. The light outputs of adjacent LED stacks would be equalized, and the potential thermal runaway failure mechanism discussed above would be eliminated.

For operation in excess of BCR402R's specified maximum voltage of 18V, one “trick” is to stack a sufficient number of LEDs between the power supply voltage  $+V_S$  and the DC input of the BCR402R (pin 3) such that the voltage seen at pin 3 is less than 18V. In other words, simply use additional LEDs to drop the voltage fed to the BCR402R below its maximum rating, and then finish up the string of LEDs with additional LEDs placed between pin 2 and ground, in the usual way. Refer to **Figure 7**. Note that the exact number of diodes required for the top or “voltage dropping” stack of LEDs ( $D_1, D_2, \dots D_N$ ) will depend on

- 1) the supply voltage  $+V_S$  and
- 2) the voltage drops across the particular LEDs being used. (Red, Amber, Blue and White LEDs have varying diode forward voltages.)

When used in this way, the BCR402R acts as a “current sink” for the diodes  $D_1, D_2, \dots, D_N$  on the top stack of LEDs, and as a “current source” for the diodes below, e.g.  $D_{N+1}, D_{N+2}, \dots, D_{N+X}$ . As there is only one current path, stabilization is maintained for both upper and lower stacks of LEDs. There is a vanishingly small difference or “error” in terms of the current difference between LEDs in the top stack and the bottom stack, this difference being created by the base current consumed by the internal PNP transistor in the BCR402R. This base current, and therefore the current difference between top and bottom LED stacks, is only about 400 microamps at a nominal 20mA LED current. As such, the human eye will not be able to discern any differences in brightness in LEDs between top

and bottom stacks due to this effect. In fact, there is far more variation in brightness between individual LEDs of the same type, if they are all driven with identical currents, than could be attributed to this small “error” current due to the BCR402R’s PNP transistor base current.

In closing, for either the high voltage application, or standard application, an external NPN transistor (Q1) may be used as an ON / OFF switch for the LED circuit, if desired. Infineon Technologies markets a broad range of switching transistors suitable for this purpose, and the best choice will depend on the voltage present at pin 1 of the BCR402R, e.g. select a switching transistor with sufficient collector-emitter and collector-base breakdown voltages.

**Figure 7. Operation of BCR402R at “High” Voltages e.g. > 18V.**

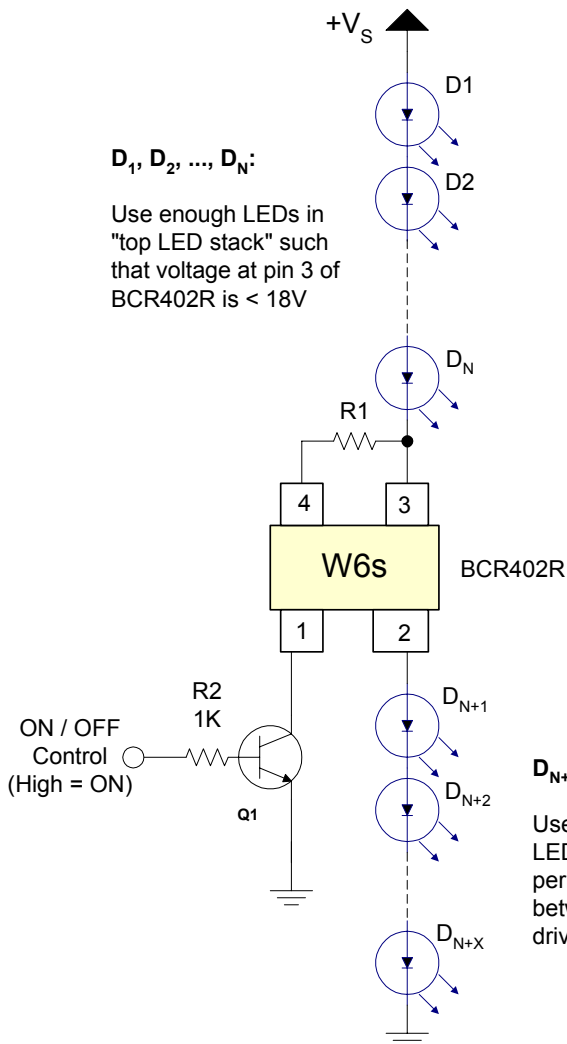

Note: maximum possible number of LEDs that can be used in entire circuit depends upon  $+V_S$  & voltage drop across particular diode types. Q1 and R2 are optional, if it is desired to switch LED stack on and off at this point. If switch is not needed, ground pin 1 of BCR402R. Be sure Q1 can handle voltage present at pin 1 of BCR402R given the value of  $+V_S$  selected. Infineon produces a broad range of switching transistors suitable for Q1.

#### 4. Temperature Compensation, Negative Temperature Coefficient of BCR402R and Protection of LEDs from Thermal Runaway

For this section, please refer to the internal schematic diagram of the BCR402R shown in **Figure 8** below.

Note that, as a rough rule-of-thumb, the base-emitter forward junction voltage of a Silicon PN junction has a temperature coefficient of something like  $-2.3 \text{ mV} / ^\circ\text{C}$ . In other words, as temperature increases, the emitter-base voltage of the internal PNP transistor in BCR402R decreases at a rate of about 2 millivolts per degree C.

**Figure 8. BCR402R Internal Schematic (inside box formed by dotted line)**

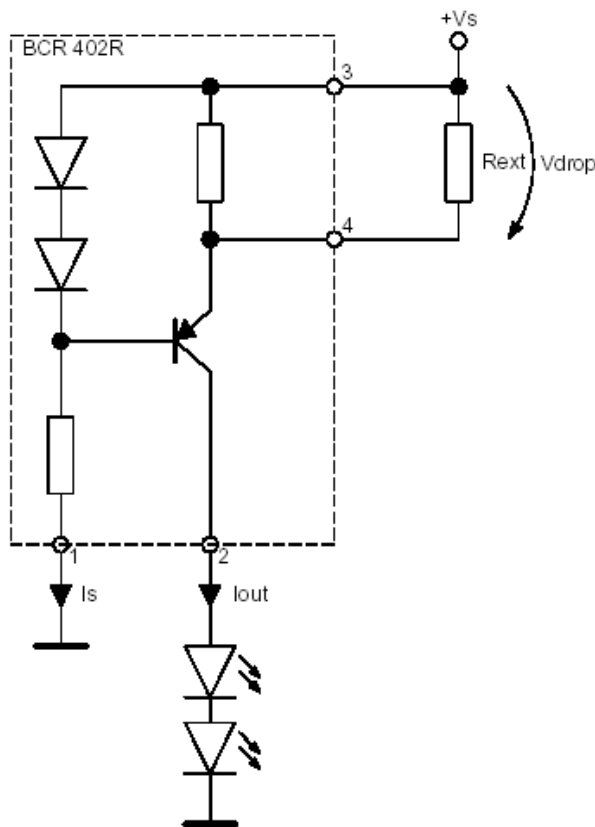

Ordinarily, this temperature coefficient could create the following problem: for a given operating point, as we go from cold to hot, the PNP transistor's  $V_{BE}$  will decrease, making the transistor "turn on harder", thereby making the

BCR402R provide more current from pin 2 ( $I_{OUT}$ ) as we get hotter, creating the potential to have a thermal runaway condition in our LED display circuit. To prevent this, two internal series diodes are placed between the  $+V_S$  node and the internal PNP transistor's base. Since each of these two internal diodes also has a temperature coefficient of the same value ( $-2.3 \text{ mV} / ^\circ\text{C}$ ), as we go hotter, the PNP transistor's base voltage will rise, tending to "throttle back" the PNP transistor. If only one diode junction were used, we would more or less evenly temperature compensate for the PNP transistor's B-E junction and maintain a fairly constant BCR402R output current over temperature. The addition of the second diode "over-compensates" or actually causes the BCR402R to "source" slightly less current as one goes hot – providing negative feedback and thereby preventing a potentially dangerous thermal runaway condition for the LEDs in the display circuit. This is especially useful for LED displays subjected to wide temperature variations, e.g. those found in automotive applications.

#### 5. PCB Layout Details

The top view of the Application Board is given in **Figure 9** on the next page. An enlarged picture including component placement is provided in **Figure 11** on page 7. Note that there are two positions in which to place R1, in order to accommodate either 0402 or 1208 case size resistors. Open connections to ground on the left of the LED stack make it easy to modify the board for use with less than four LEDs. **Figure 10** on the next page shows an enlarged view of the PCB section where the LED driver is placed. The top and bottom metal layers are shown. This reveals the heat sink (metal area) for the BCR402R on the backplane or bottom metal layer of the PC board. The PC board footprint was designed to fit the SOT143R package used by BCR401R and BCR402R, but it will also accommodate the SC74 package as used by the BCR405U without modification. Please note that this particular PCB does not accommodate the "High Voltage" application described in **Section 3**.

Figure 9. Top View of Application PC Board.

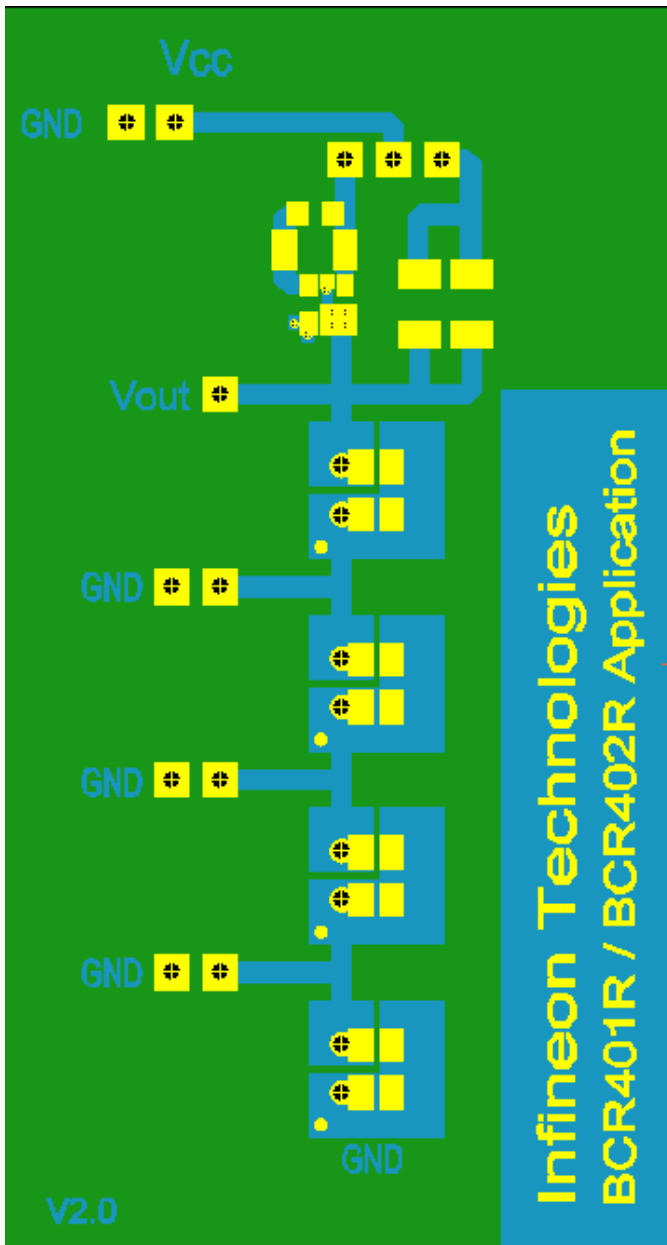

Figure 10. Close-In View of Top Metal Layer with “Heat Sink” on Backplane.

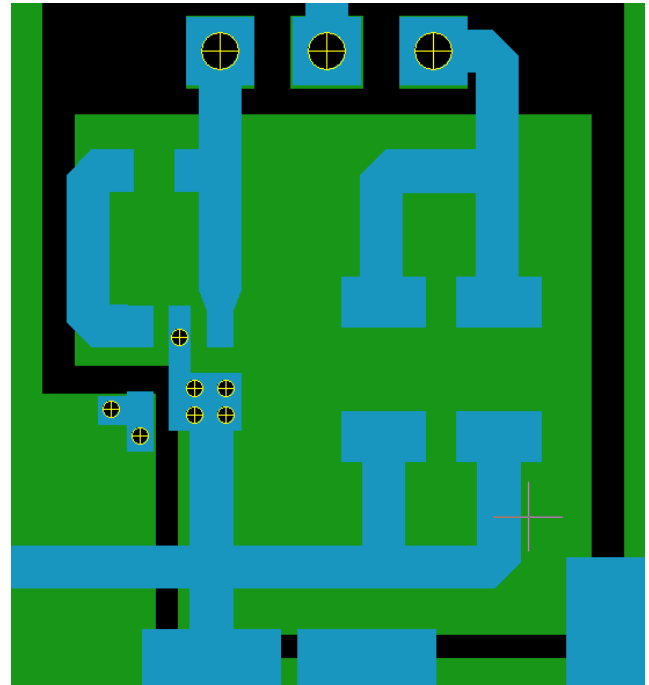
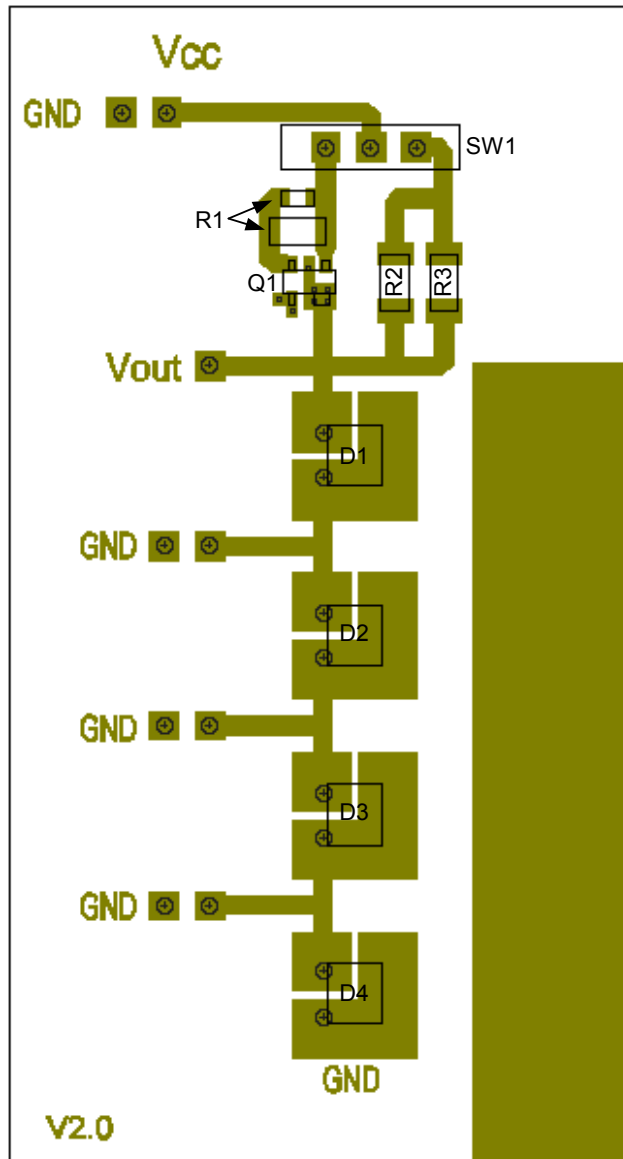

Figure 11. Enlarged Top View of PCB Showing Parts Placement.



Board size: 35mm x 65mm  
 Board material: FR4  
 Board thickness: 1mm

## 6. Conclusions

Infineon Technologies' LED Driver family offers the end user an easy, cost-effective way to stabilize LED current in fixed, portable or automotive LED display applications. DC power consumption is minimized, as compared to LED driver circuits employing resistors for current stabilization. The negative temperature coefficient of these LED Drivers helps to prevent thermal runaway conditions in LED displays.

## 7. References

[1] Application Note 077, "Thermal Resistance Calculations", Infineon Technologies AG, Silicon Discretes Group. (App note gives overview of thermal overstress issues. Available at [http://www.infineon.com/cmc\\_upload/documents/039/975/Appli077.pdf](http://www.infineon.com/cmc_upload/documents/039/975/Appli077.pdf) ).